



## LxG-LP12xx LOW PROFILE OPTICAL TRANSCEIVER

OC3 / STM1 SONET / SDH Applications  
 3.3V, 1310nm FP Laser, Singlemode,  
 Up to 15 KM Distance

### FEATURES

- Low Profile Design - 0.386 inches max. height
- Surface mount I/O pins for high speed signal integrity
- All metal body, solder or screw mount options
- Industrial Temp Range, Vibration tolerant design
- Individual (separate) +3.3 V power supply per port
- Industry standard duplex multimode LC receptacle
- Full compliance Bellcore / Telcordia GR-253
- EN-60825/ IEC-825 / CDRH Class 1 Compliant
- Optional Parylene C Conformal Coating

### APPLICATIONS

The LxG-LT12xx multimode optical fiber transceivers provide low profile, cost effective solutions for OC-3 or STM1 singlemode optical fiber data links with a duplex LC connector interface.

These transceivers are fully compliant with Bellcore / Telcordia GR-253 standards but can be used for any other data communications purpose within their operating parameters.

### DESCRIPTION

The LxG-LT12xx fiber optic transceivers consist of transmitter and receiver functions combined in a Low Profile RJ Format module. The optical transmitter is a 1310nm FP laser. The transmitter input lines are driven with differential LVPECL signals applied to the Transmit (TX+ and TX-) pins. These signals are internally converted to a suitable modulation current by a CMOS integrated circuit. A Transmit Disable (TDIS) function is provided to enable control of the optical output.

The optical receivers consist of PIN and Preamplifier assemblies and CMOS limiting post-amplifier integrated circuits. Outputs from the receivers consist of differential CML data signals on the Receive (RX+ and RX-) pins and a single ended LVTTTL signal detect function on the Signal Detect (SD) pin. The RX data is squelched (JAM) upon Signal Detect deassert to prevent garbage data output when no optical signal is present.

### BLOCK DIAGRAM

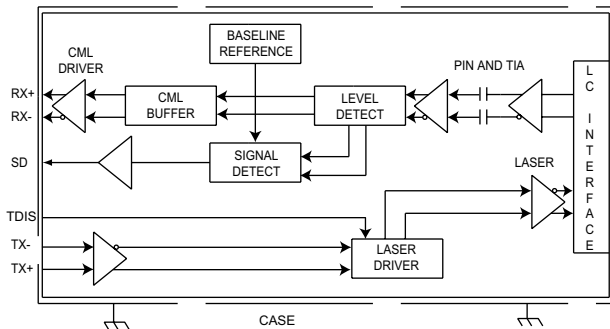

### ORDERING INFORMATION

**L X G - LP 12 X X**

Product Family	Shell Options	Application	Optical Wavelength, Signal Detect, Fiber	Temperature and Coating	Mounting
<b>L=</b> Low Profile RJ XCVR	<b>N=</b> No GND Tabs (Flat Shell)	<b>G=</b> OC3 / STM1 (155 Mbps)	<b>LP12=</b> 1310 nm Singlemode, LVPECL Signal Detect 3.3VDC Power	<b>H=</b> -40 to 85 C, No Coating	<b>BLANK=</b> Solder Posts (0.125 length)
	<b>T=</b> GND Tabs			<b>M=</b> -40 to 85 C, Conformal Coating	<b>B=</b> Screw Posts (0.50 length)

**L \_ \_ G - LP 12 \_ \_**



# LxG-LP12xx LOW PROFILE OPTICAL TRANSCEIVER

OC3/STM1 Sonet and SDH Compliant Applications

3.3V, 1310nm FP Laser, Singlemode, Up to 15.0 Km

## ABSOLUTE MAXIMUM RATINGS

Absolute maximum limits mean that no catastrophic damage will occur if the product is subjected to these ratings for short periods, provided each limiting parameter is in isolation and all other parameters have values within the performance specification. It should not be assumed that limiting values of more than one parameter can be applied to the product at the same time.

Parameter	Symbol	Minimum	Typical	Maximum	Unit
Storage Temperature	$T_S$	-55		+100	°C
Lead Soldering Temperature	$T_{SOLD}$			+260	°C
Lead Soldering Time	$t_{SOLD}$			10	Seconds
Supply Voltage	$V_{CC}$	-0.5		+4.5	V
Data Input Voltage	$V_I$	-0.5		$V_{CC}$	V
Differential Input Voltage (p-p)	$V_D$			2.2	V
Output Current	$I_O$			50	mA

## RECOMMENDED OPERATING CONDITIONS

Parameter	Symbol	Minimum	Typical	Maximum	Unit
Operating Temperature Limit	$T_A$	-40		+85	°C
Supply Voltage	$V_{CC}$	+3.135		+3.465	V
TX Common Mode Voltage	$V_{CM}$		2.0		V
TX Differential Input Voltage (p-p)	$V_D$	0.20		2.20	V
Transmit Disable Voltage	$V_{TD}$	2.0		$V_{CC}$	V
Transmit Enable Voltage	$V_{TEN}$	$V_{EE}$		0.8	V
RX Data Output Load	$R_L$		50		Ohms

## DETAIL OF DATA I/O STAGES

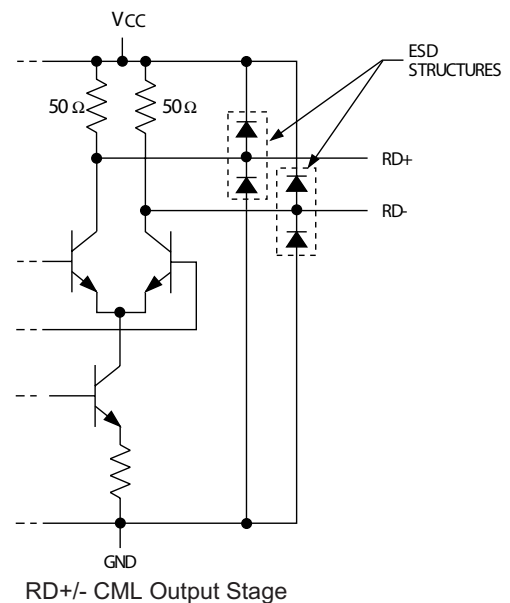
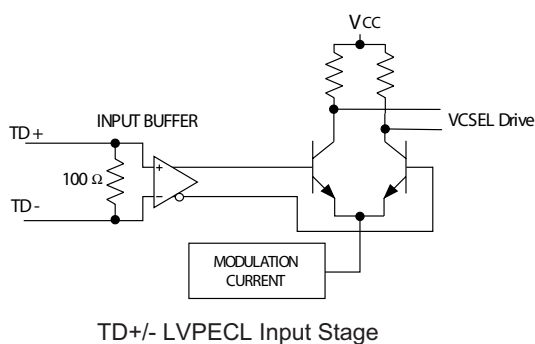

# LxG-LP12xx LOW PROFILE OPTICAL TRANSCEIVER

OC3/STM1 Sonet and SDH Compliant Applications

3.3V, 1310nm FP Laser, Singlemode, Up to 15.0 Km

## TRANSMITTERS

VCCTX = 3.15V to 3.45V,  $T_A$  = Operating Temperature Range

Parameter	Symbol	Minimum	Typical	Maximum	Unit
Optical Output Power <sup>1</sup>	$P_o$	-15		-8	dBm
Optical Output Wavelength	$\lambda_{OUT}$	1263	1310	1360	nm
Spectral Width	$\Delta\lambda_{RMS}$			4.0	nm
Extinction Ratio	ER	8			dB
Supply Current	$I_{CC}$		120	160	mA
Optical Rise / Fall Time (20% - 80%)	$t_{R,F}$			0.26	nS
Relative Intensity Noise	RIN			-117	dB/Hz
Coupled Power Ratio	CPR	9			dB
Total Jitter	TJ			187	pS
Transmit Disable Voltage	$V_D$	$V_{CC}-1.3$		$V_{CC}$	V
Transmit Enable Voltage	$V_{EN}$	$V_{EE}$		$V_{EE}+0.8$	V

BER=10<sup>-10</sup> @ 155.52Mbps, PRBS 2<sup>23</sup>-1, NRZ, Compliant with Telcordia GR-253 and ITU recommendations G.957 and G.958

## RECEIVERS

VCCR<sub>X</sub> = 3.15V to 3.45V,  $T_A$  = Operating Temperature Range

Parameter	Symbol	Minimum	Typical	Maximum	Unit
Optical Sensitivity <sup>1</sup>	$P_I$	-32	-35	-8	dBm
Optical Input Wavelength	$\lambda_{IN}$	1270		1355	nm
Optical Return Loss	ORL	12			dB
Supply Current	$I_{CC}$		70	120	mA
Signal Detect Assert Time	$t_{SDAS}$		<10	100	$\mu$ S
Signal Detect Deassert Time	$t_{SDDA}$		<10	350	$\mu$ S
Signal Detect Deassert Level	$SD_{OFF}$	-45			dBm
Signal Detect Assert Level	$SD_{ON}$			-32	dBm
Signal Detect Hysteresis	HYS	1.5	2.25	3.5	dB
RX Data Output - Low	$V_{OL} - V_{CC}$	-1.810		-1.475	V
RX Data Output - High	$V_{OH} - V_{CC}$	-1.165		-0.880	V

BER=10<sup>-10</sup> @ 155.52Mbps, PRBS 2<sup>23</sup>-1, NRZ, Compliant with Telcordia GR-253 and ITU recommendations G.957 and G.958

# LxG-LP12xx LOW PROFILE OPTICAL TRANSCEIVER

OC3/STM1 Sonet and SDH Compliant Applications  
3.3V, 1310nm FP Laser, Singlemode, Up to 15.0 Km

## CONFORMAL COATING OPTION

Parameter	Value
Specification	MIL-I-46058C, Type XY
Coating:	Parylene type C
Deposition:	Vacuum deposited
Film Thickness:	1 MIL +/- 0.0002

## REGULATORY COMPLIANCE

Requirement	Feature	Condition	Notes
MIL-STD-883-3015.7	ESD	Class II	2200V
IEC-801-2	ESD	Human Body Model	25KV
IEC-801-3	EMI	Immunity	10V/M
FCC	EMI	Class B	>20dB
EN 55022 (CISPR 22A)	EMI	Class B	10V/M
IEC-825 Issue 1993-11	Eye Safety	Class 1	TUV Certificate Number One File
FDA CDRH 21-CFR 1040	Eye Safety	Class 1	CDRH Accession Number On File

# LxG-LP12xx LOW PROFILE OPTICAL TRANSCEIVER

OC3/STM1 Sonet and SDH Compliant Applications

3.3V, 1310nm FP Laser, Singlemode, Up to 15.0 Km

Low Profile Optical Transceiver  
Top View Shown

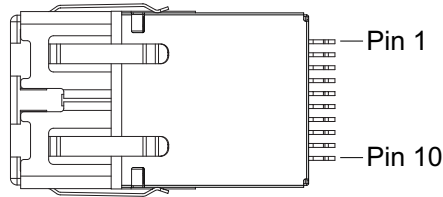

## PIN FUNCTIONS

Pin Number	Symbol	Description	Logic Family
GP	GP	Grounding Posts Connect to chassis ground	N/A
1	TD+	Transmitter DATA In	LVPECL
2	VEETX	Transmitter Signal Ground	N/A
3	TD-	Transmitter DATA In	LVPECL
4	VCCTX	Transmitter Power Supply	N/A
5	SD	Signal Detect output Satisfactory Optical Input: Logic "1" Output Fault Condition: Logic "0" Output	LVPECL
6	TDIS	Transmit Disable input Logic 1 = Disable Optical Output Logic 0 = Enable Optical Output Internal 4.7K ohm pull-down (enable)	LVTTTL
7	RD+	Receiver DATA Out	CML
8	VCCR <sub>X</sub>	Receiver Power Supply	N/A
9	RD-	Receiver DATA Out	CML
10	VEER <sub>X</sub>	Receiver Signal Ground	N/A

# LxG-LP12xx LOW PROFILE OPTICAL TRANSCEIVER

OC3/STM1 Sonet and SDH Compliant Applications

3.3V, 1310nm FP Laser, Singlemode, Up to 15.0 Km

## Application Schematic

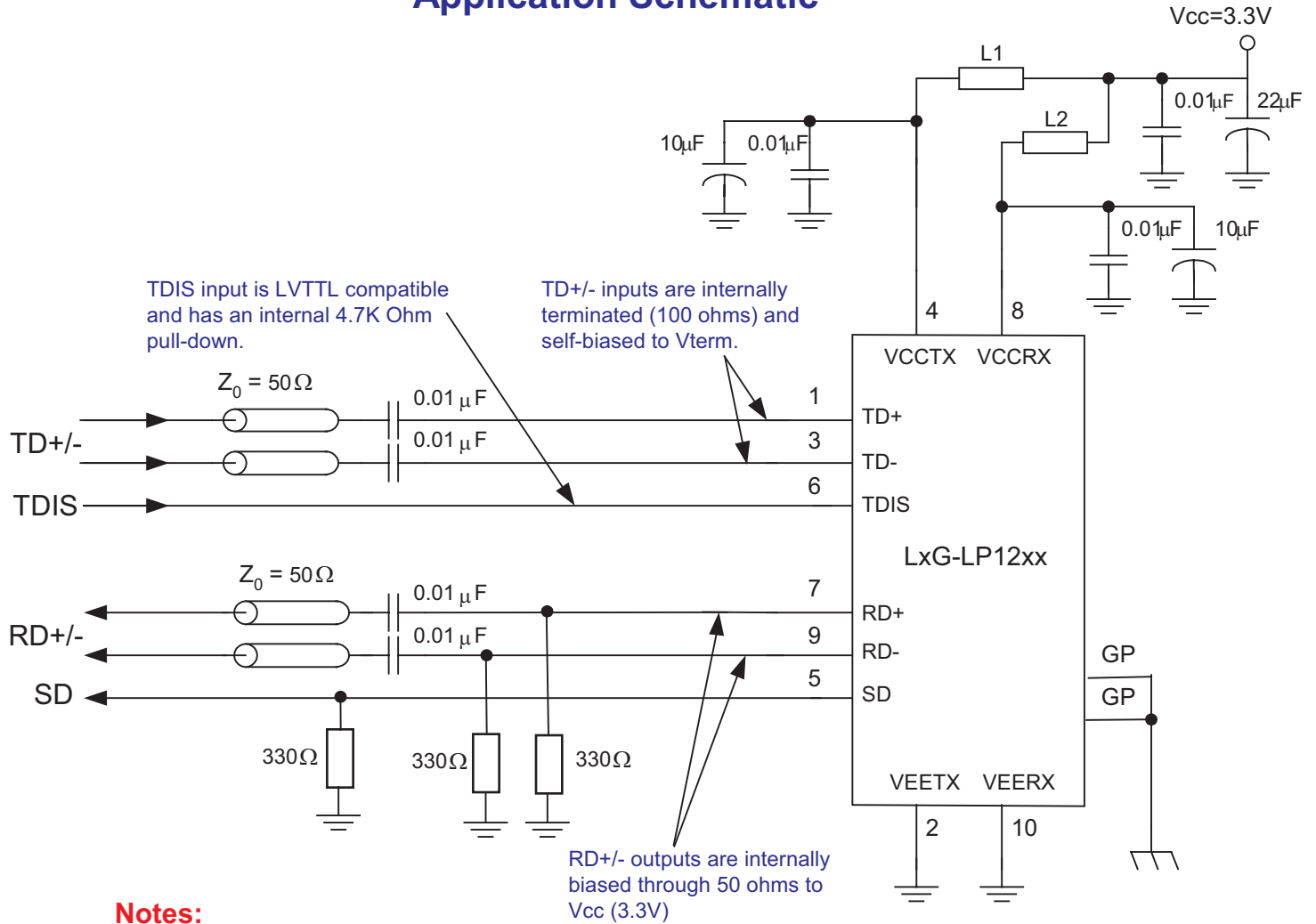

# LxG-LP12xx LOW PROFILE OPTICAL TRANSCEIVER

OC3/STM1 Sonet and SDH Compliant Applications  
 3.3V, 1310nm FP Laser, Singlemode, Up to 15.0 Km

## LOW PROFILE OPTICAL TRANSCEIVER PCB FOOTPRINT

Dimensions Are Shown As:  $\frac{\text{mm}}{\text{(inches)}}$

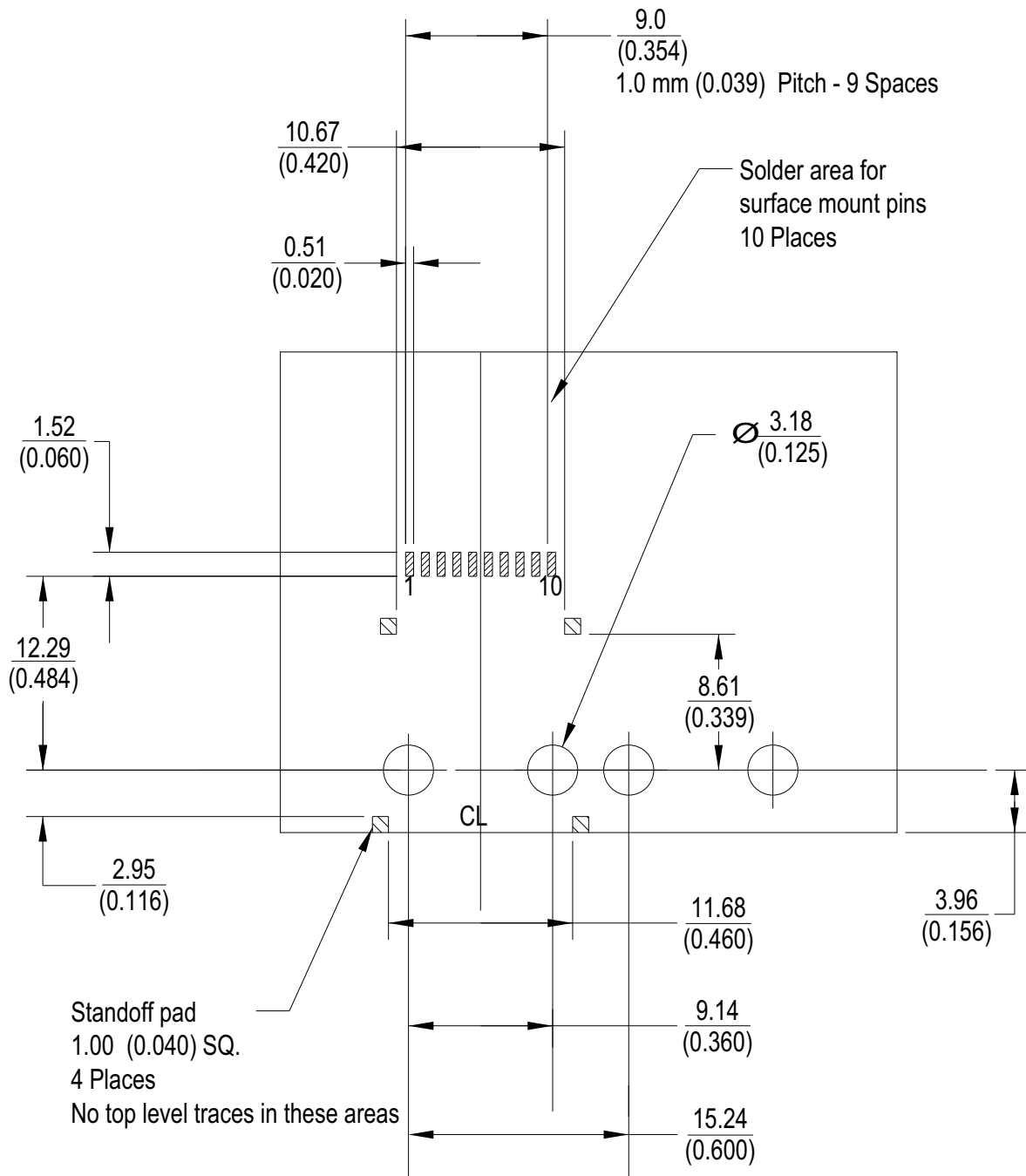

Top View Shown



7444 West Wilson Avenue, Chicago, IL 60706 USA  
 Telephone: 708.867-9600, Fax: 708.867-0996  
 Webpage: www.stratoslightwave.com

TDS-215G-003  
 December 10, 2004

# LxG-LP12xx LOW PROFILE OPTICAL TRANSCEIVER

OC3/STM1 Sonet and SDH Compliant Applications  
3.3V, 1310nm FP Laser, Singlemode, Up to 15.0 Km

## MECHANICAL DETAIL (SOLDER POST VERSION)

GROUND CLIP SHELL

FLAT SHELL

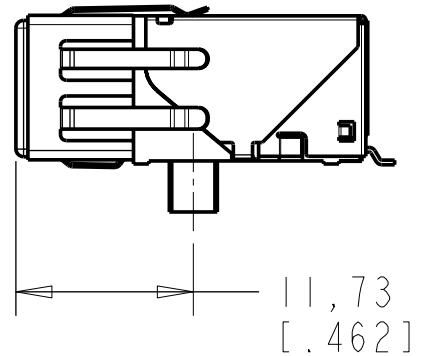
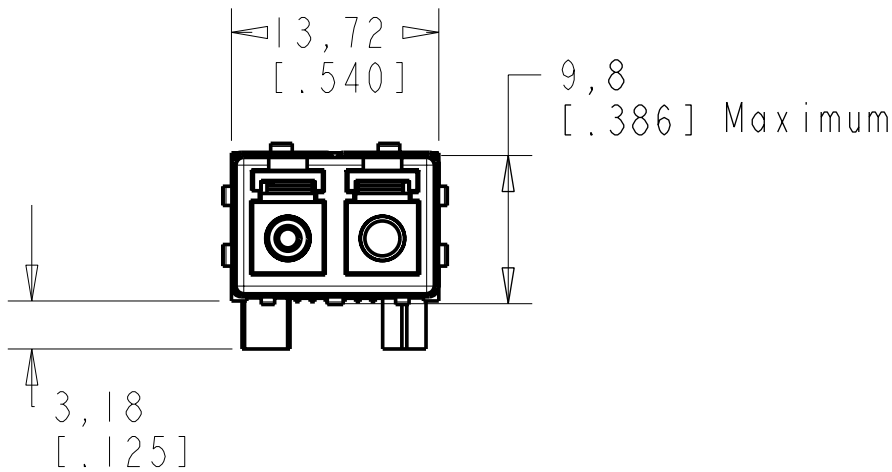
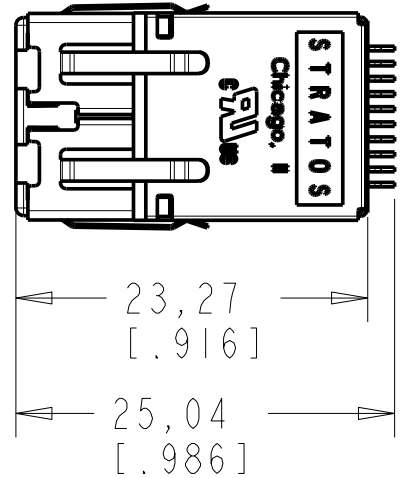
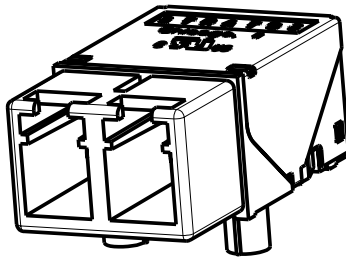
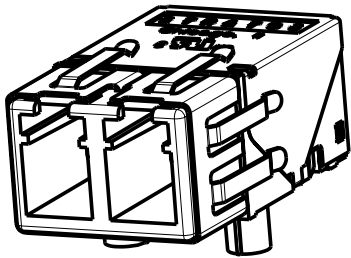

RECOMMENDED PANEL CUT-OUT  
for PROPER GROUND CLIP CONTACT  
is 0.400 X 0.560 INCHES.

# LxG-LP12xx LOW PROFILE OPTICAL TRANSCEIVER

OC3/STM1 Sonet and SDH Compliant Applications  
3.3V, 1310nm FP Laser, Singlemode, Up to 15.0 Km

## MECHANICAL DETAIL (SCREW POST VERSION)

GROUND CLIP SHELL

FLAT SHELL

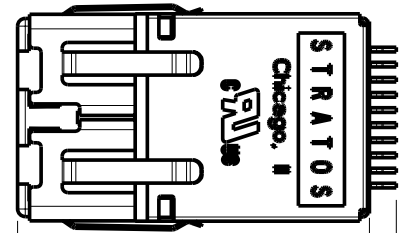
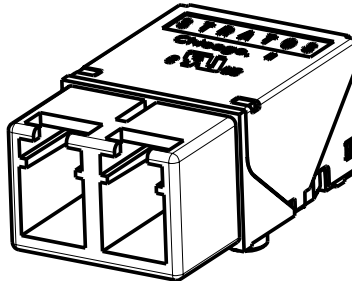
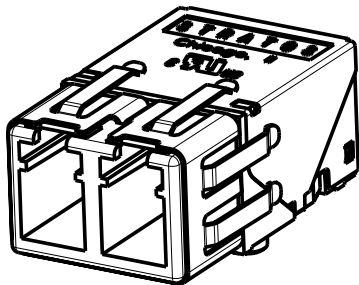

23,27  
[.916]

25,04  
[.986]

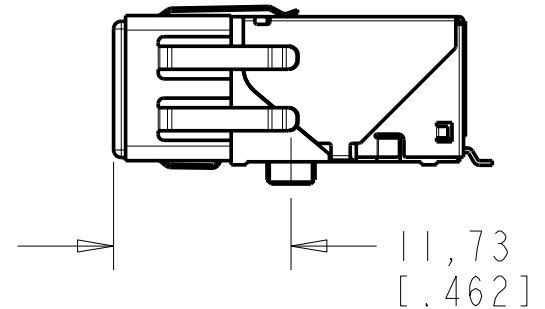
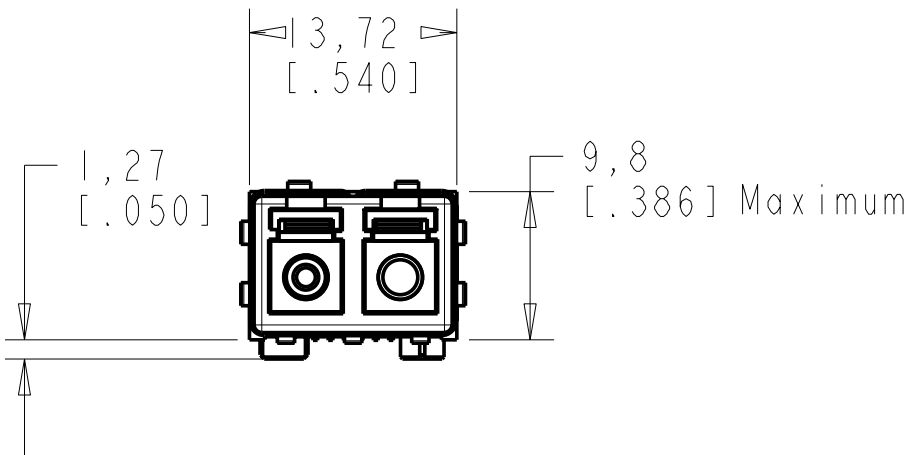

RECOMMENDED PANEL CUT-OUT  
for PROPER GROUND CLIP CONTACT  
is 0.400 X 0.560 INCHES.

STRATOS

7444 West Wilson Avenue, Chicago, IL 60706 USA  
Telephone: 708.867-9600, Fax: 708.867-0996  
Webpage: [www.stratoslightwave.com](http://www.stratoslightwave.com)

TDS-215G-003  
December 10, 2004

# LxG-LP12xx LOW PROFILE OPTICAL TRANSCEIVER

OC3/STM1 Sonet and SDH Compliant Applications  
 3.3V, 1310nm FP Laser, Singlemode, Up to 15.0 Km

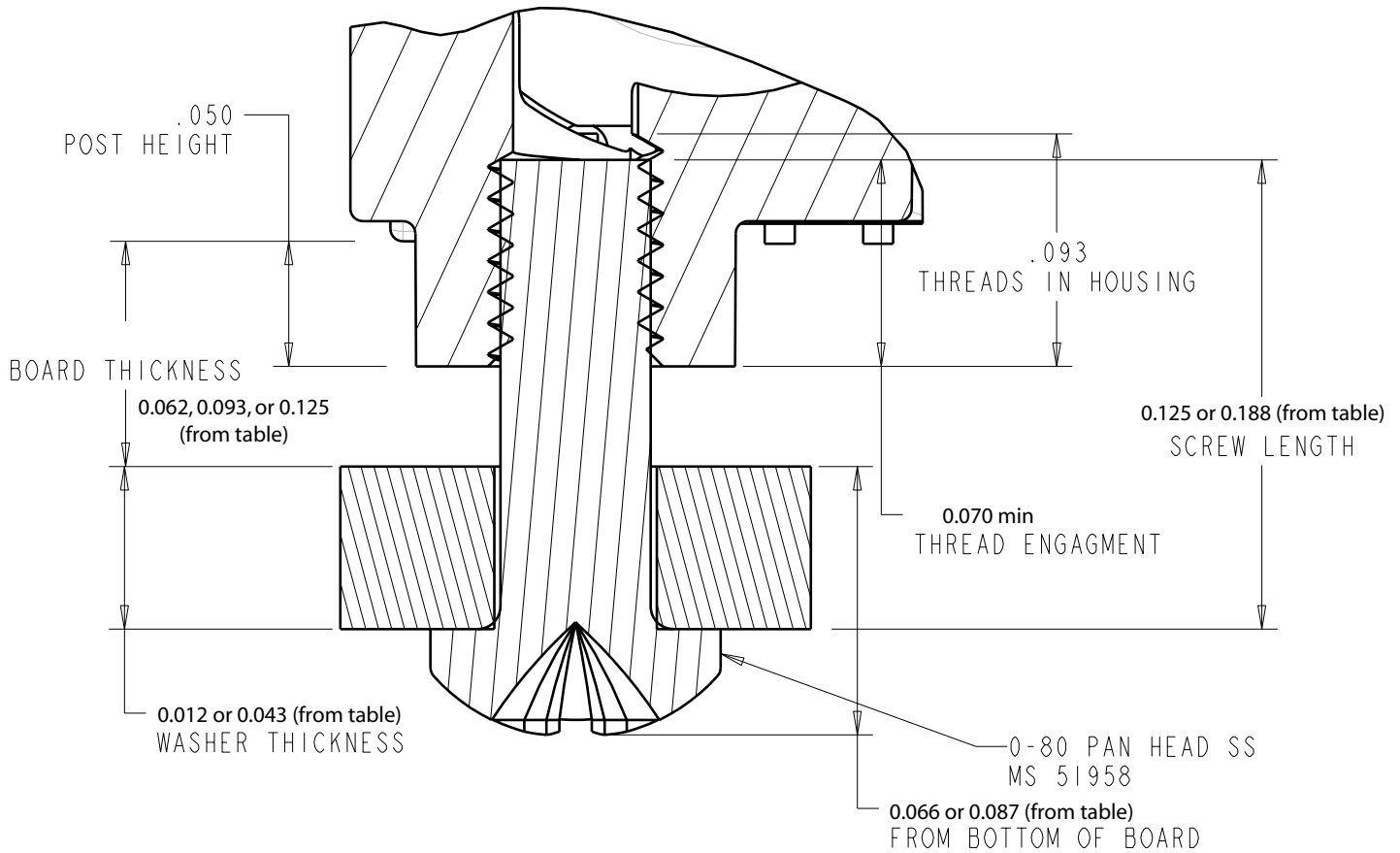

PCB Nominal Thickness	Screw Length	Washer Thickness	Screw/Washer Height	Order Stratos Washer	Order Stratos Screw
0.062 in +/- 0.005	0.125 in	0.043 in	0.087 in	751-00002	618-00001
0.093 in +/- 0.005	0.125 in	0.012 in	0.066 in	751-00001	618-00001
0.125 in +/- 0.005	0.188 in	0.043 in	0.087 in	751-00002	618-00002

**Notes:**

1) Customer may choose to any type 0-80 Stainless Steel (SS) screw configuration (pan head, flat head, hex head, etc) as long as the thread engagement is less than 0.93 inches max into the Low Rider housing.

2) Customer can order 0-80 SS pan head screws and washers from Stratos for standard sized PCB thicknesses as identified in the table. The Stratos part number is identified for the screw/washer combination for each of three standard sized PCB thicknesses. Be sure to order 2 washers and 2 screws per Low Rider device.

3) Torque screws to 7 to 9 in-oz for a clamping force of 36 to 47 lbs per screw. Do not exceed 16 in-oz torque per screw.



7444 West Wilson Avenue, Chicago, IL 60706 USA  
 Telephone: 708.867-9600, Fax: 708867-0996  
 Webpage: www.stratoslightwave.com

# LxG-LP12xx LOW PROFILE OPTICAL TRANSCEIVER

OC3/STM1 Sonet and SDH Compliant Applications

3.3V, 1310nm FP Laser, Singlemode, Up to 15.0 Km

## PART NUMBER SUMMARY AND OPTIONS

Part Number	Flat Shell	Clip Shell	Conf Coat	Solder Posts	Screw Posts
LNG-LP12H	X			X	
LNG-LP12M	X		X	X	
LNG-LP12HB	X				X
LNG-LP12MB	X		X		X
LTG-LP12H		X		X	
LTG-LP12M		X	X	X	
LTG-LP12HB		X			X
LTG-LP12MB		X	X		X

## IMPORTANT NOTICE

Stratos Lightwave, Inc. reserves the right to make changes to or discontinue any optical link product or service identified in this publication, without notice. Stratos Lightwave recommends that its customers obtain the latest version of the publications to verify, before placing orders, that the information being relied on is current. Stratos Lightwave warrants performance of its optical link products to current specifications in accordance with the Stratos Lightwave standard warranty. Testing and other quality control techniques are utilized to the extent that Stratos Lightwave has determined it to be necessary to support this warranty. Specific testing of all parameters of each optical link product is not necessarily performed on all optical link products. Stratos Lightwave products are not designed for use in life support appliances, devices, or systems where malfunction of a Stratos Lightwave product can reasonably be expected to result in a personal injury. Stratos Lightwave customers using or selling optical link products for use in such applications do so at their own risk and agree to fully indemnify Stratos Lightwave for any damages resulting from such improper use or sale. Stratos Lightwave assumes no liability for Stratos Lightwave applications assistance, customer product design, software performance, or infringement of patents or services described herein. Nor does Stratos Lightwave warrant or represent that a license, either expressed or implied is granted under any patent right, copyright, or intellectual property right, and makes no representations or warranties that these products are free from patent, copyright, or intellectual property rights. Applications that are described herein for any of the optical link products are for illustrative purposes only. Stratos Lightwave makes no representation or warranty that such applications will be suitable for the specified use without further testing or modification.

STRATOS

7444 West Wilson Avenue, Chicago, IL 60706 USA  
Telephone: 708.867-9600, Fax: 708867-0996  
Webpage: [www.stratoslightwave.com](http://www.stratoslightwave.com)

TDS-215G--003  
December 10, 2004